

Comparison of Shielding Effectiveness Measured by Using Absorption Clamp Method and Reverberation Chamber Method

Hailong Wang, Kai Chen, Lei Xing and Qian Xu

College of Electronic and Information Engineering
Nanjing University of Aeronautics and Astronautics
Nanjing, China

emhai@foxmail.com, Chenkay@nuaa.edu.cn,
xinglei@nuaa.edu.cn, emxu@foxmail.com

Pufei Yi

R&D Department
Nanjing Rongce Testing Technology Limited
Nanjing, China
Philip@emcdir.com

Introduction

- The shielding effectiveness of the cable can be measured by **absorbing clamp method (ACM)** and **reverberation chamber method (RCM)**.
- The **absorbing clamp** can be used to measure the power radiated from the cable under test (CUT). Due to the consistency of electromagnetic environment in **reverberation chamber (RC)**, the power of external environment coupling into CUT power can be received by the reference antenna.
- Due to the difference in characteristic impedance between the cable and the VNA, **an impedance adapter** is added. Furthermore, for the test conditions without impedance adapter, the final results are corrected by **the scattering matrix**.
- We compared the results of **shielding effectiveness** measured in different methods and states.

Measurement Setup

In this part, the schematic and the arrangement of the testing methods are shown in Fig. 1 and Fig. 2. The paired cable and the impedance adapter are shown in Fig. 3.

The characteristic impedance of the CUT is measured by TDR method. Before testing, all RF lines are calibrated with dual ports and its shielding performance is much more superior to the CUT. The background noise satisfy the standard of 6 dB lower than the value of testing.

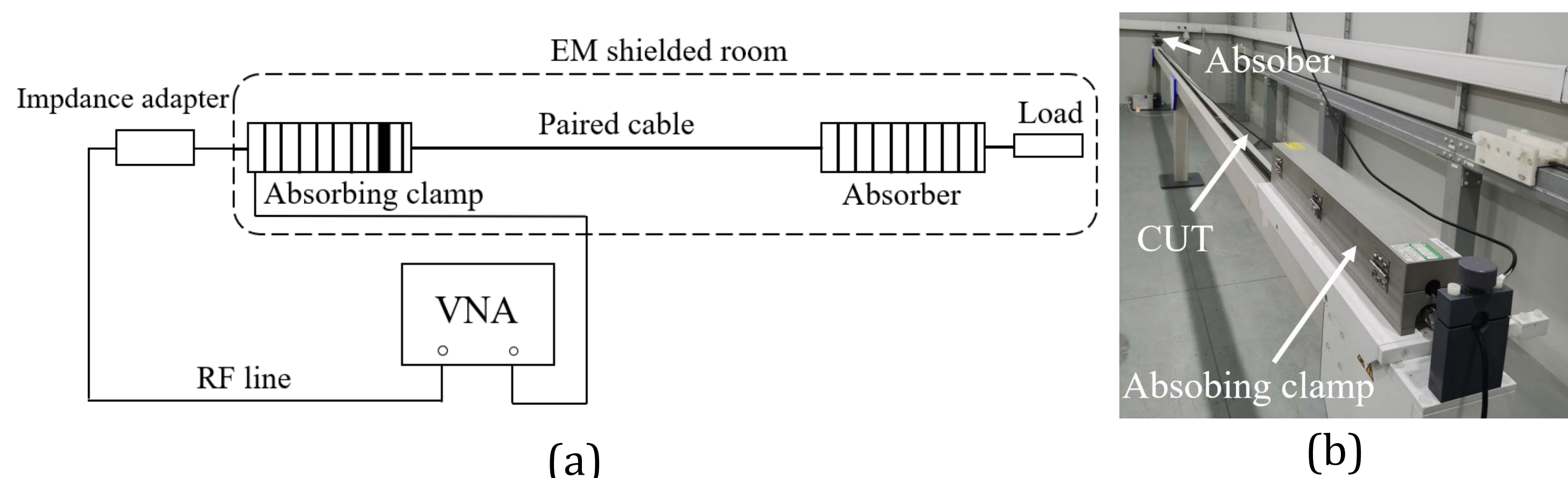

Fig. 1. (a) Absorbing clamp method, (b) Measurement in a shielded room.

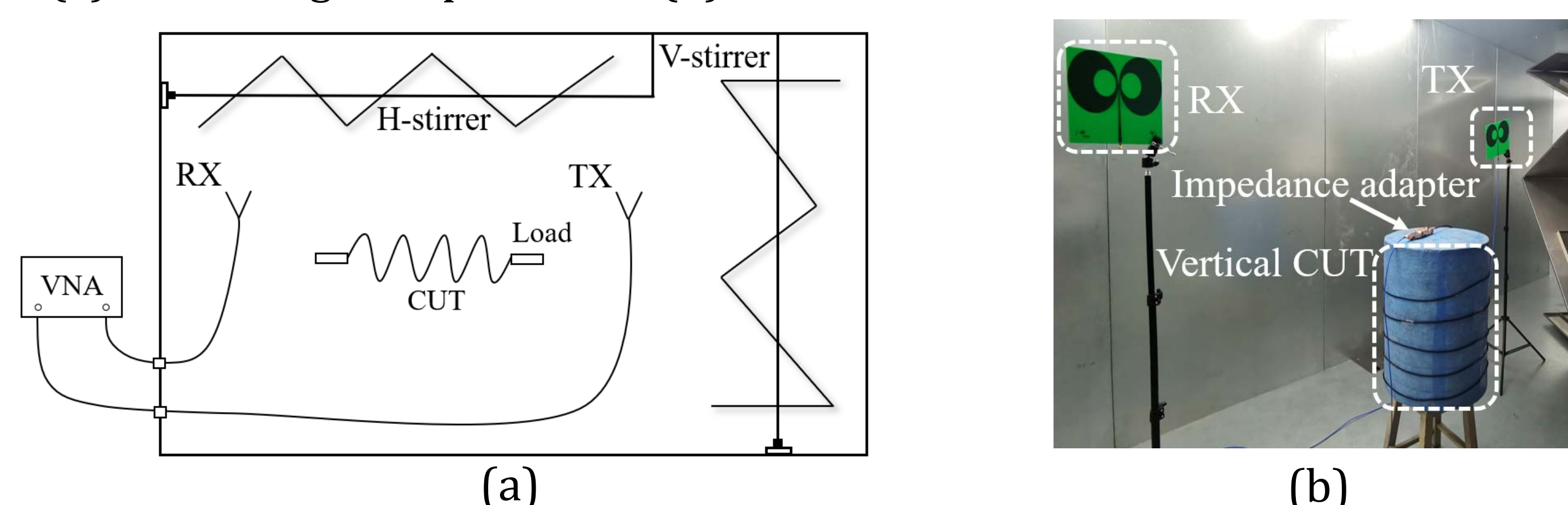

Fig. 2. (a) Reverberation chamber method, (b) Measurement in an Reverberation chamber.



Fig. 3. (a) The paired cable, (b) Impedance adapter.

Theory and Results

- In the absorbing clamp method, the screening effectiveness is defined as:

$$a_s = -10 \lg \left[\frac{P_{2max}}{P_1} \right]$$

where the P_{2max} is the peak power radiated from the cable under test (CUT) into the surroundings and P_1 is the power injected into the cable.

- The detailed formula for calculating SE is expressed as follows:

Theory and Results

$$a_c = 10 \lg_{10} \left(\frac{P_0}{\max[P_{4,n}; P_{4,f}]} \right) - a_m + 20 \lg_{10}(k_m)$$

where P_0 is the injection power, $P_{4,n}$ and $P_{4,f}$ are the peak power of the near and far end test, and a_m is the attenuation of the measuring device, including part cables, current converter, RF line inside the absorbing clamp and attenuator. k_m is the voltage gain of impedance adapter.

- In reverberation chamber method, the screening effectiveness is defined as follows:

$$a_s = -10 \lg \left[\frac{P_{DUT}}{P_{REF}} \right]$$

where the P_{DUT} is the power of external environment coupling into DUT, P_{REF} is the power received by the reference antenna.

- The detailed formula for calculating SE is expressed as follows:

$$a_s = -10 \lg_{10} \left(\frac{P_{DUT}}{P_{INJ}} \right) - \Delta_{ins} - X_L$$

where Δ_{ins} is the insertion loss of the chamber, X_L is the insertion loss of all linking devices inside and outside the chamber.

- The voltage gain of the impedance adapter can be expressed as follows:

$$k_m = \frac{R_1 R_p}{R_1 R_p + R_p R_s + R_1 R_s}$$

where R_1 is load resistance, R_s and R_p are the resistance of series and parallel resistor respectively.

- When without adding impedance adapter, the scattering matrix simplified by normalized transfer matrix is expressed as follows:

$$[S] = \frac{1}{\sqrt{\frac{Z_{01}}{Z_{02}} + \frac{Z_{02}}{Z_{01}}}} \begin{bmatrix} \sqrt{\frac{Z_{02}}{Z_{01}}} - \sqrt{\frac{Z_{01}}{Z_{02}}} & 2 \\ 2 & -\sqrt{\frac{Z_{02}}{Z_{01}}} + \sqrt{\frac{Z_{01}}{Z_{02}}} \end{bmatrix}$$

$$Loss = 20 \lg_{10}(|S_{21}|)$$

where Z_{01} is 50 Ω , Z_{02} is the characteristic impedance of the paired cable.

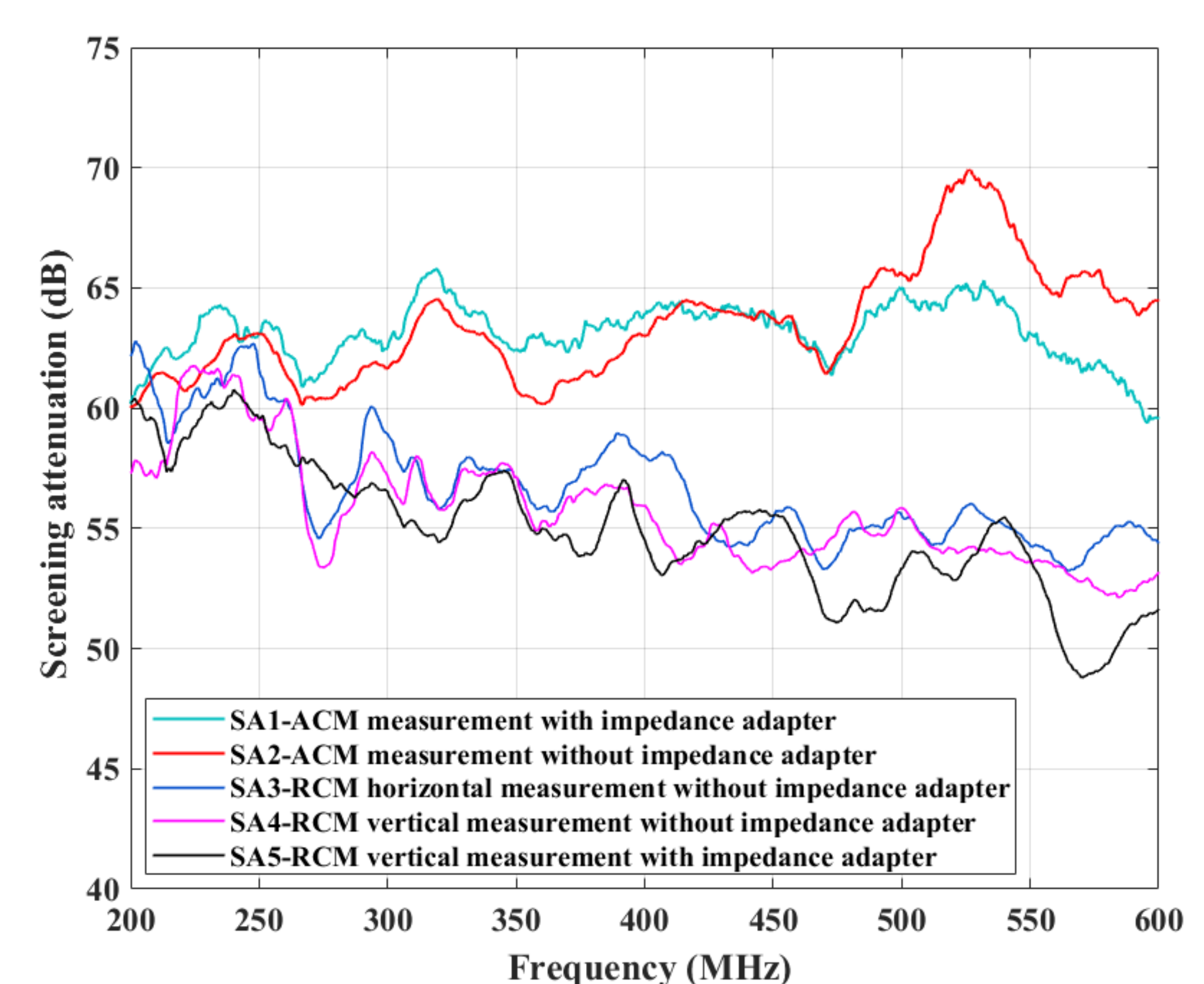

Fig. 4. Shielding effectiveness measured by using ACM and RCM..

Conclusions

- Under RCM and ACM, the SE calculated with scattering matrix is lower than that calculated with voltage gain in most frequency band. It means that new errors could be introduced for the existence of impedance adapter.
- The SE is insensitive to the polarization of CUT in RC. The difference could be produced through the change of height during movement.
- The shielding effectiveness measured by ACM is higher than that measured by RCM, and the difference between them increases with frequency.
- The ACM could have different coupling mechanism compared with the cable radiation in an RC, which leads different results.